

TUBE:
 FIN:
 HEADER:
 CONNECTION:
 CASE:

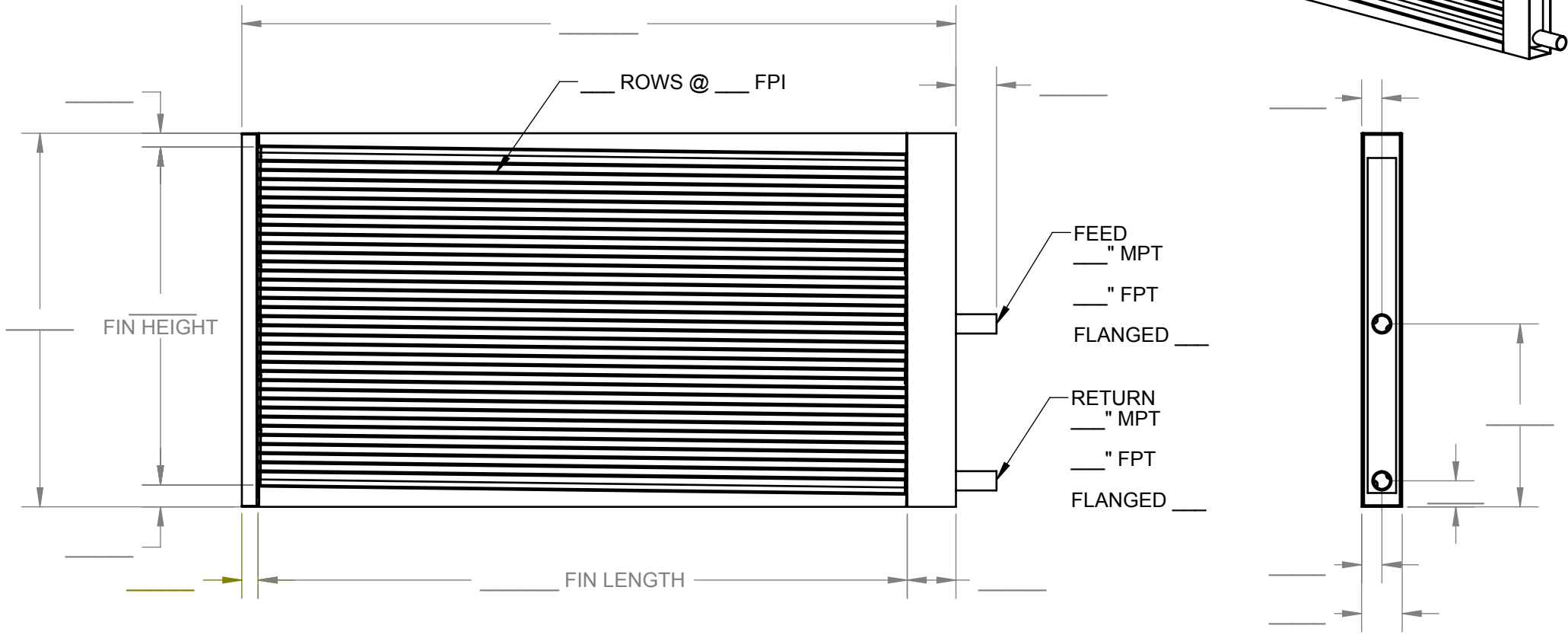
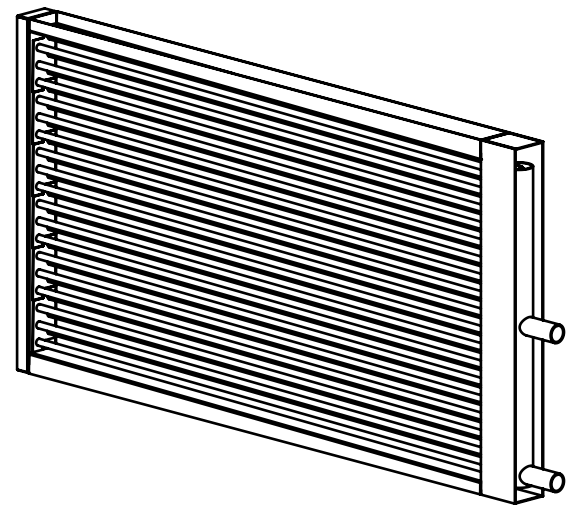

DS	DWG. NO.								
	SHEET								
BP	REV								
	DATE								
	DESCRIPTION								
	BY								

Advanced coil
 Technology, LLC

TOLERANCES UNLESS NOTED	MACH	WELD	FAB	FINISH
FRACTION	1/32	1/8	1/16	REMOVE BURRS & SHARP EDGES
DECIMAL	.03	.125	.06	DO NOT SCALE DRAWING
ANGLE	1/2°	1°	1°	

DRAWING DESCRIPTION	
STEAM COIL MODEL DS - BAFFLE PITCHED CASE	
MATL:	SQ. IN:
WIDTH:	LENGTH:
BEND ALLOW.	

THIS DRAWING IS THE EXCLUSIVE PROPERTY OF ADVANCED COIL TECHNOLOGY, LLC AND MAY NOT BE REPRODUCED OR DISTRIBUTED WITHOUT EXPRESS WRITTEN CONCENT.	
DRAWN BY:	DATE:
CHECKED BY:	DATE:
APPROVED BY:	DATE:
DWG. NO. DS	SHEET BP